

MBS-403



The Features

MBS-403 is to process R.S.T Phaes earthing line for Panel Board.
There is no mold trouble with the unit by built-in special safety.
Mold Box to prevent mold damage of loss and to keep good maintenance.
Over ten times as accurate and fast as existence method in processing because of simultaneous working of MBS-403 RST earthing main line.

* The evening sunlight/Specification

Max. Power Pressure	280kgs/cm ²
Max. Size of Steel Plate	280kgs/øcm ²
Max. Punching Hole	ø112mm, 112×112mm in rectangular
The hole dimension is available according to customer's requirement	

[↑ TOP](#)

* Mould Sets



Mein Piercing

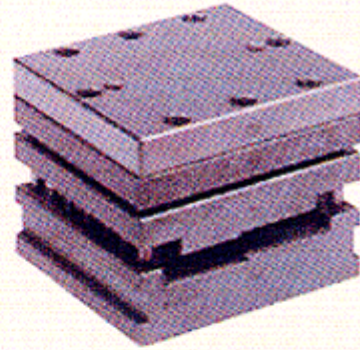

103E, R상
103E, R-Phase

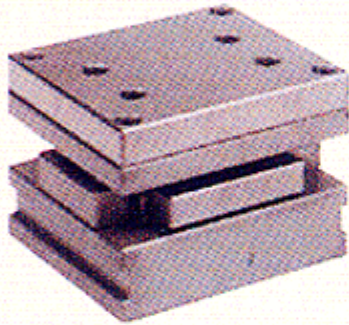

203R상
203, R-Phase

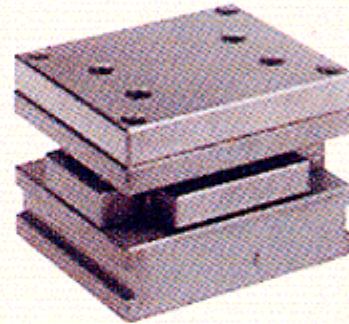

ELB, BF, 32GR상
ELB, BF, 32GR Phase

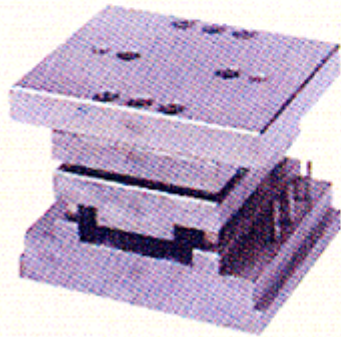

ES상
ES Phase

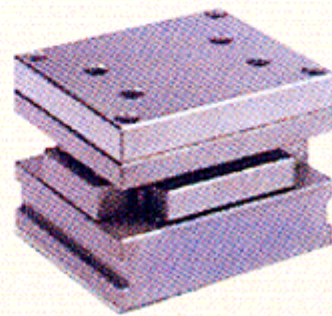

메인접지타공
Main earthing hole

[↑TOP](#)

* Plucky fight half price worker completion condition

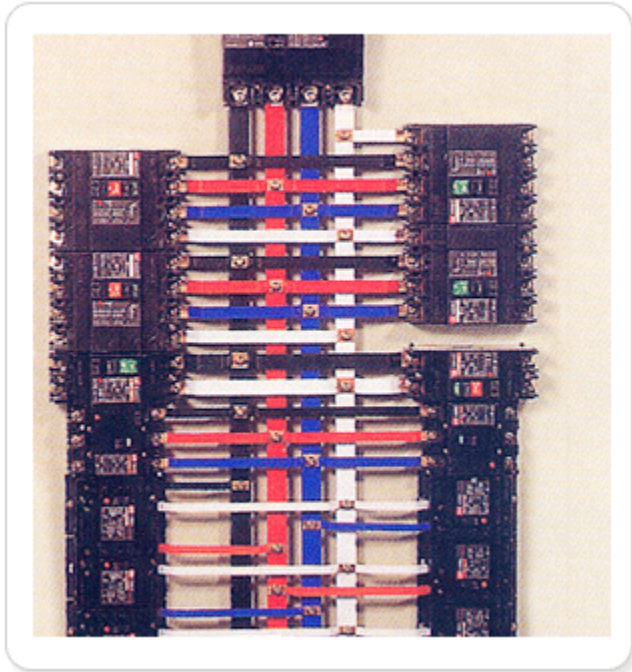

[↑TOP](#)

* Minute general unit sprouting processing work

* Minute general Mainie other worker



ONE-TOUCH PAOCESSING OF BUSBAR



MAIN PIERCHING

[↑TOP](#)

* BusBar Workpieces Formed ley Mould Sets

