

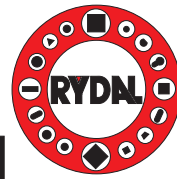

RYDAL



PRECISION TOOLS

SPECIALIST TURRET PRESS TOOLING MANUFACTURERS

Distributed by:

FOREMOST

Machinery Corporation

425 Huehl Road, Northbrook, Illinois 60062 USA

Tel: 847 272 7880 Fax: 847 272 7948

www.foremostmachinery.com

Punch Round
Part No.BBRP
\$73.44

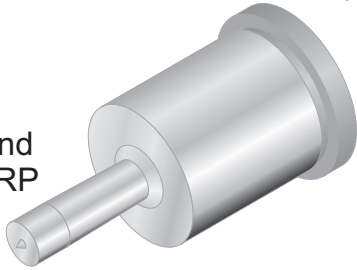

Punches are manufactured from High Speed Steel with back tapered tips as standard.



Punch Shape
Part No.BBSP
\$112.20

Die Round
Part No.BBRD
\$126.30



Dies are supplied as standard with Slug Retainer Ribs in aperture to prevent "slug pulling"

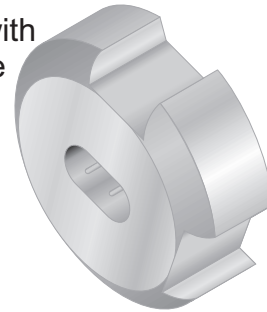
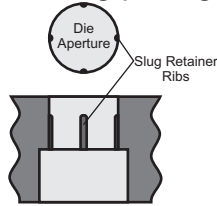

Die Shape
Part No.BBSD
\$193.80

Stripper Round
Part No.BBRS
\$126.48

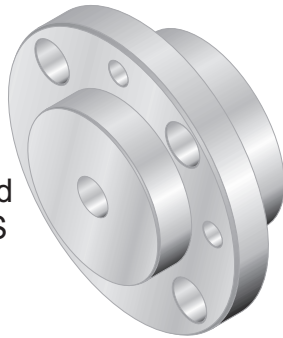

Stripper/Guides are manufactured from pre toughend wear resistant steel to ensure positive guidance and alignment of punch tip.

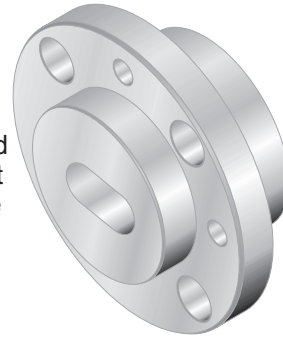

Stripper Shape
Part No.BBSS
\$193.80

Split Cylinder Retainers
Part No. BBSR
\$153.00

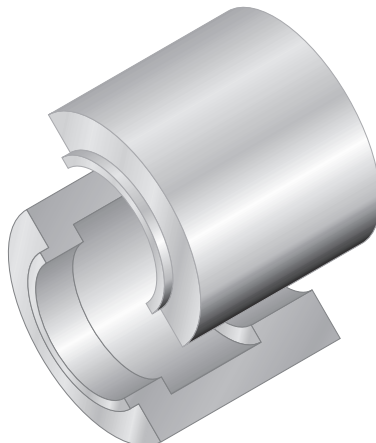

ADDITIONS:-

Extra Locations add **\$25.50** per location.